

ASSEMBLY INSTRUCTIONS FOR:

COMPACT-X70

EUCRL X2 SA | EUCRL X3 SA | EUCRL X2 BN | EUCRL X3 BN | EUCRL X3 F SA | EUCRL X3 F BN

EUCRL XSB KIT

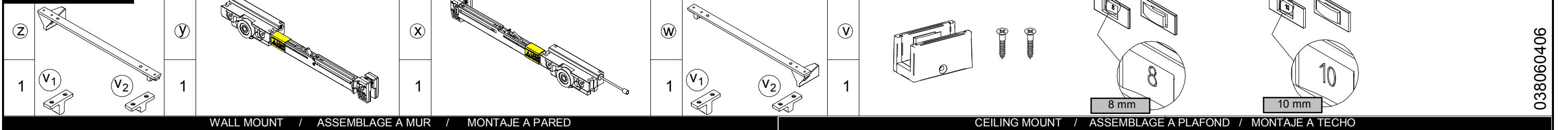

WALL MOUNT / ASSEMBLAGE A MUR / MONTAJE A PARED

CEILING MOUNT / ASSEMBLAGE A PLAFOND / MONTAJE A TECHO

038060406

EUCRL X2
EUCRL X3

! *BEFORE INSTALLING DECIDE WHICH MOUNTING OPTION BETWEEN 1 OR 2

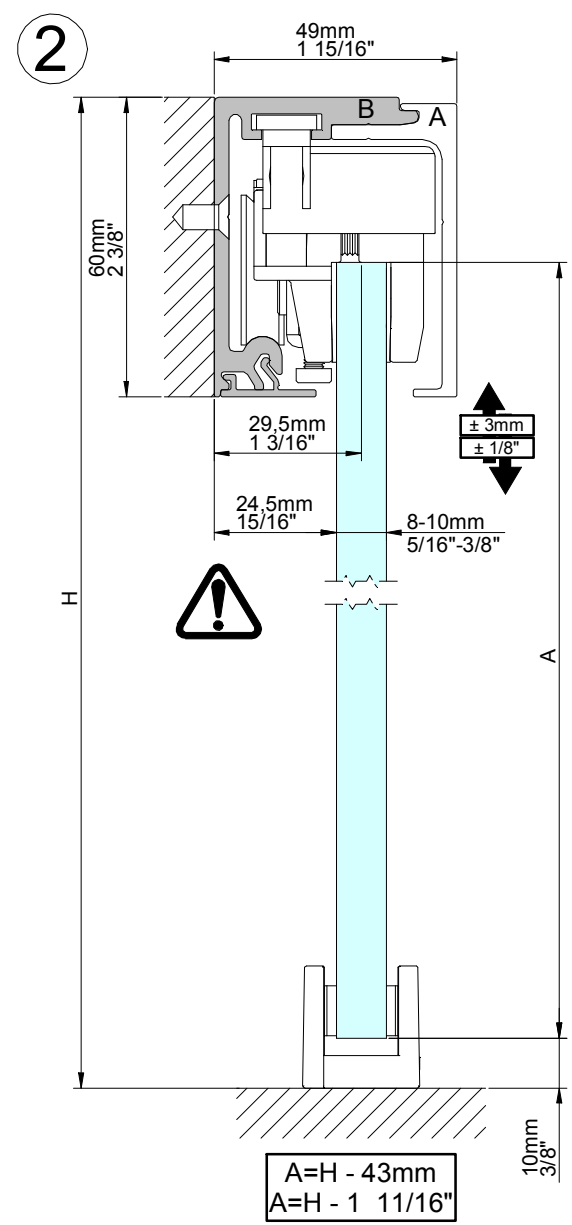
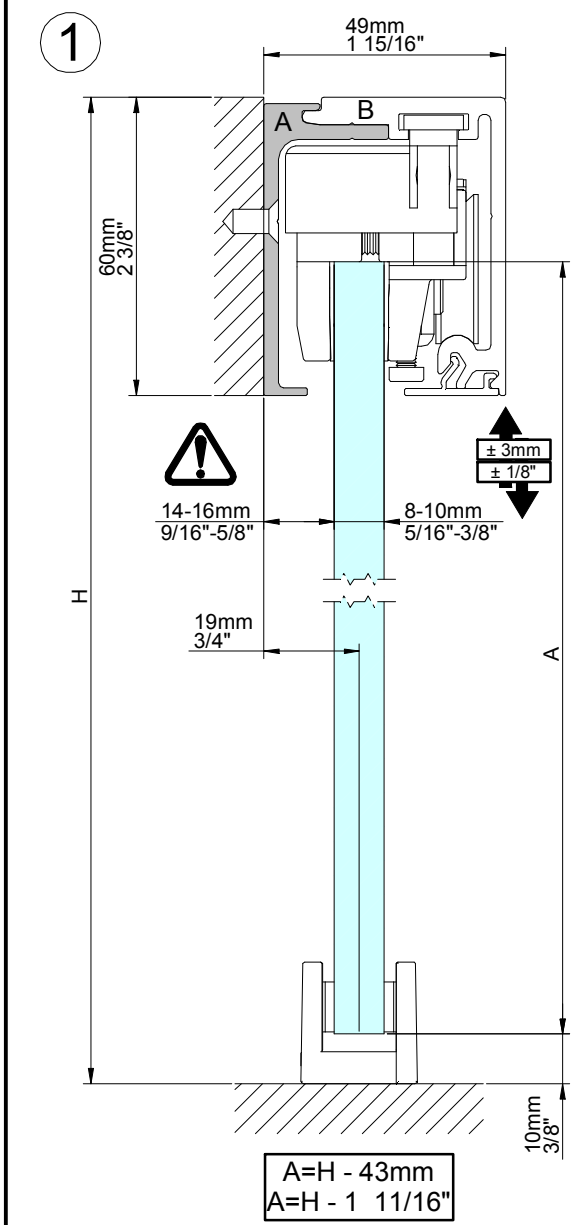

EUCRL X2
EUCRL X3

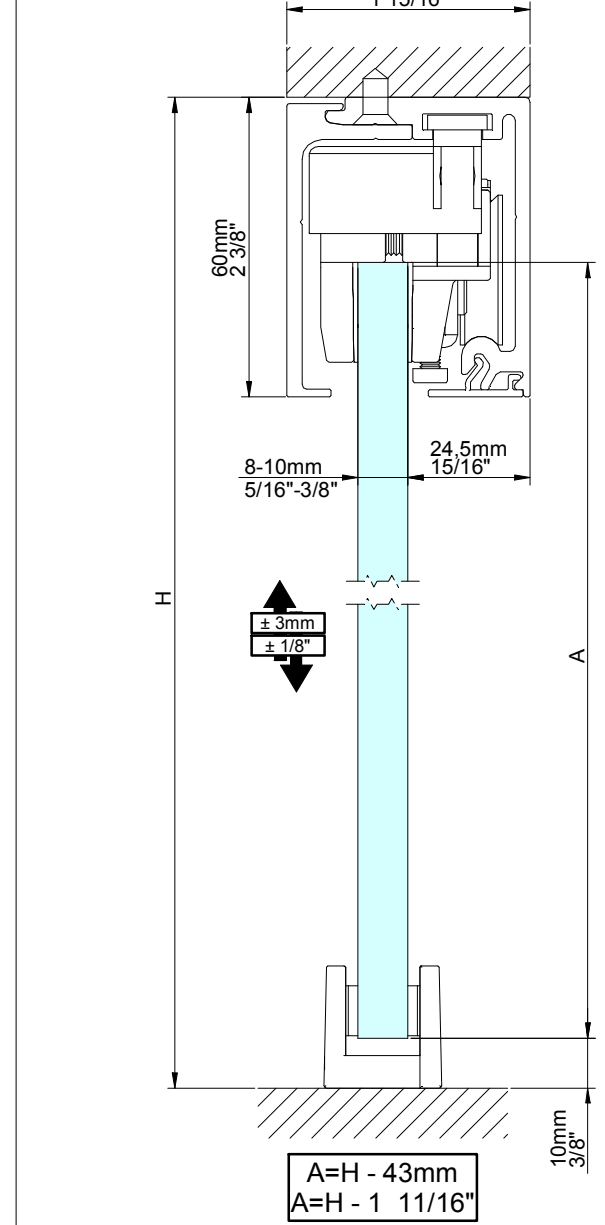

EUCRL X3 F

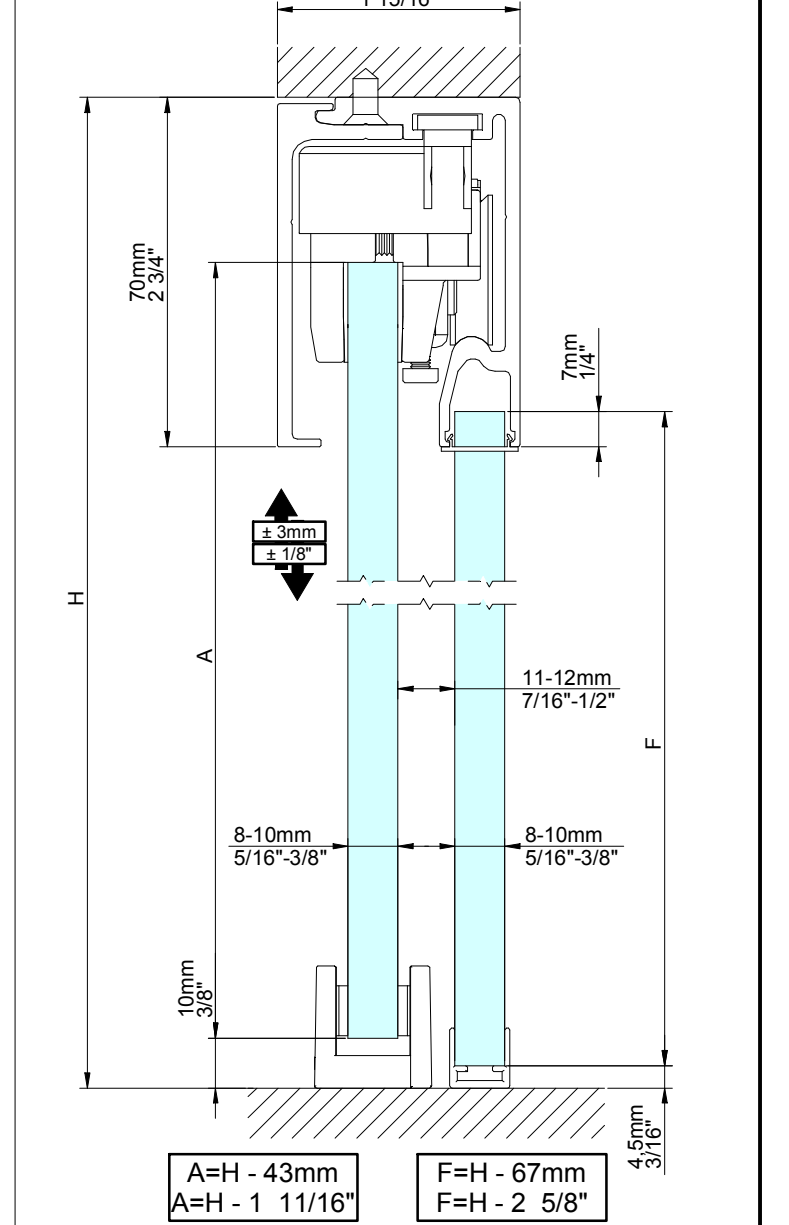

ASSEMBLY INSTRUCTIONS FOR:

COMPACT-X70

EUCRL X2 SA | EUCRL X3 SA | EUCRL X2 BN | EUCRL X3 BN | EUCRL X3 F SA | EUCRL X3 F BN

CLAMPS ASSEMBLY / ASSEMBLAGE PINCES / MONTAJE PINZAS

1mm - 1/16" ↔ 8mm - 5/16"
3mm - 1/8" ↔ 10mm - 3/8"

(x4) GLASS THICKNESS SETTINGS SCREW
ANTI-SHOCK SCREW
ANTI-DERAILMENT SCREW
13 N/m
CLAMP TIGHTEN SCREWS
HEIGHT ADJUSTMENT SCREW

WALL MOUNT / ASSEMBLAGE A MUR / MONTAJE A PARED

*CHOOSE BETWEEN OPTION 1 OR 2

6 200mm 7 7/8"
100mm 3 15/16"
200mm 7 7/8"

7 5.25mm 3/16"

5 *If mounted between walls insert softbrake stopper now, as seen in picture n°11
PRE-DRILLING / PRE-MECANISÉ / PRE-MECANIZADO
5.25mm 3/16"
8mm 5/16"

IMPORTANT!
*T-SHAPE ACTIVATOR HAVE TO BE LOADED AS SHOWN TO WORK CORRECTLY.
335.35mm 13 3/16"
43mm 1 11/16"
43mm 1 11/16"
675mm MIN 26 9/16"

10
11

12 V1...V2
V1 8.5mm 5/16" X ≤ 8mm
V2 12.5mm 1/2" X > 8mm

13 14 15 DON'T REMOVE FLOOR SPACERS

16 *LIFT/HOLD GLASS DURING HEIGHT ADJUSTMENT
±3mm ± 1/8"

ANTI-DERAILMENT / ANTI-DÉRAILLEMENT / ANTIDESCARRILAMIENTO

17 18 19 20 21 22 Ok!

ASSEMBLY INSTRUCTIONS FOR:

COMPACT-X70

EUCRL X2 SA | EUCRL X3 SA | EUCRL X2 BN | EUCRL X3 BN | EUCRL X3 F SA | EUCRL X3 F BN

CEILING MOUNT / ASSEMBLAGE A SOSTRE / MONTAJE A TECHO

23 PRE-DRILLING / PRE-MECANISÉ / PRE-MECANIZADO

24 **25** **26** **27** *FOLLOW INSTALLATION FROM STEP 13

CEILING MOUNT WITH FIXED GLASS / ASSEMBLAGE A SOSTRE AVEC VERRE FIXE / MONTAJE A TECHO CON VIDRIO FIJO

EUCRL X3 F

28 **29** **30** **31** **32** **33** *FOLLOW INSTALLATION FROM STEP 13

GLASS WALL MOUNT / ASSEMBLAGE A MUR DE VERRE / MONTAJE A PARED DE VIDRIO

EUCRL X GF KIT Includes 5 Un

34 **35** **36** **37** **38** **39** **40** *FOLLOW INSTALLATION FROM STEP 13

INSTALLATIONS VARIANTS / VARIANTES D'INSTALLATION / VARIANTES DE INSTALACION

23 **28** **34** **35** **36** **37** **38** **39** **40**

Ø5,25mm 3/16"

200mm 7 7/8"

100mm 3 15/16"

5,25mm 3/16"

10mm 3/8"

10,5mm 7/16"

26mm 1"

15mm 5/8"

49mm 1 15/16"

23,75mm 15/16"

60mm 2 3/8"

8-10mm 5/16"-3/8"

14-16mm 9/16"-5/8"

10mm 3/8"

29mm 1 1/8"

10,5 13,9

200mm 7 7/8"

100mm 3 15/16"

A=H - 43mm
A=H - 1 11/16"

G=H + X

2m -> 10 Un (EUCRLXGFKIT x 2)
3m -> 15 Un (EUCRLXGFKIT x 3)

MAX. 70 kg.

MAX. 154 lbs.

8 -> 10mm 5/16" -> 3/8"

! DONT REMOVE FLOOR SPACERS

! CUT TO SIZE

! FOLLOW INSTALLATION FROM STEP 13

ASSEMBLY INSTRUCTIONS FOR:

COMPACT-X70

EUCRL X2 SA | EUCRL X3 SA | EUCRL X2 BN | EUCRL X3 BN | EUCRL X3 F SA | EUCRL X3 F BN

Compact X Sliding Door Installation Instructions.

Measure aperture height and calculate glass size before proceeding with the installation – the glass height calculation can be found on page 1 of the enclosed assembly instructions.

The following instructions are based on a single door wall or ceiling fixed application without fixed side panels.

1. Unpack and check all items are correct within the boxes as per enclosed assembly instructions.
2. Measure aperture / wall length and cut top track to suit.
3. Remove front cover, mark and drill holes for wall fixing screws (use scribed line on inside of track as a guide – the track can be used as a wall or ceiling fixed system).
4. Place top track in position mark wall / ceiling for fixing holes – drill wall / ceiling for appropriate fixings.
5. Slide actuators into top track (items W & Z) the actuators can be fitted with 2 different height T shape stops depending on the final height of the glass – these can be changed at any time. (see step 12 of the enclosed assembly instructions)
6. Fix top track to wall or ceiling using appropriate fixings.
7. Place glass horizontal onto a table and fit clamps / soft close assemblies (items X & Y) see step 1, 2 & 4 of the enclosed assembly instructions. (ensure the clamps are set for the correct glass thickness).
8. Hang glass onto the top track and make sure glass is perpendicular (ensuring the soft close actuators are "loaded" see step 4 of the enclosed instructions) and mark position for bottom guide.
9. Split the guide and fit the L shaped section behind the glass in the position marked.
10. Ensure guide is straight and fit front plate of guide ensuring glass slides freely.
11. Using height adjustment screws situated on the top clamps, adjust height of the door and ensure the door is square. See step 2 & 16 of the enclosed instructions.
12. Position the actuators in the track left and right to the correct position – lock grub screws to secure.
13. Adjust anti derailment screws on the clamps to stop the glass jumping. See step 2 & 19 of the enclosed assembly instructions.
14. Test door for smoothness and correct operation.
15. Fix front cover and end caps if required.

For fixed panel installations please cut and fix the supplied u channel in position directly underneath the fixed panel u channel of the top track, the fixed panel should be fixed in position using silicone sealant.

To fix the top track to a glass façade please follow glass fabrication and top track fabrication details, see step 33 & 34 of the enclosed assembly instructions.